

## HEATER FOR UNIVERSAL OIL TYPE



## **INSTALLATION AND** **MAINTENANCE MANUAL**

## 1. Purpose

The universal oil heater is intended for heating industrial premises (workshops, car services, industrial halls, warehouses, livestock buildings, basements, garages, etc.). The furnace can operate on most waste oils, e.g. engine oil, gear oil, hydraulic oil, diesel oil, HBO I, II and III type oils with a viscosity not higher than SAE 80.

**DO NOT USE TRANSFORMER OILS  
THEY MAY CONTAIN SUBSTANCES HARMFUL TO THE OPERATION OF THE MACHINE**

### TECHNICAL DATA

<b>Maximum capacity *</b>	<b>kW</b>	<b>30</b>
<b>Minimum capacity*</b>	<b>kW</b>	<b>8</b>
<b>Max oil consumption</b>	<b>l/h</b>	<b>3,0</b>
<b>Min oil consumption</b>	<b>l/h</b>	<b>0,8</b>
<b>Heated air flow</b>	<b>m<sup>3</sup> / h</b>	<b>1460</b>
<b>Electrical supply</b>	<b>V/Hz</b>	<b>230/50</b>
<b>Max power consumption</b>	<b>W</b>	<b>100</b>
<b>Exhaust outlet diameter</b>	<b>mm</b>	<b>130</b>
<b>Width</b>	<b>mm</b>	<b>920</b>
<b>Height</b>	<b>mm</b>	<b>1350</b>
<b>Length</b>	<b>mm</b>	<b>540</b>
<b>Weight</b>	<b>kg</b>	<b>50</b>

\* Thermal efficiency given for fuel with the following parameters:

- heating value = 42,6 MJ/kg.
- density at 15°C max. = 860 kg/cm<sup>3</sup>.

With higher parameters, the thermal efficiency may increase up to 33 kW

SERIAL NO. / YEAR OF PRODUCTION NUMER FABRYCZNY / ROK PRODUKCJI	
UNIVERSAL OIL HEATER NAGRZEWNICA NA OLEJE UNIWERSALNE	
	
TYPE TYP	
MAX CAPACITY MAKSYMALNA WYDAJNOŚĆ	30 kW
MIN CAPACITY MINIMALNA WYDAJNOŚĆ	8 kW
AIR FLOW PRZEPLYW POWIETRZA	1460 m <sup>3</sup> / h
FUEL PALIWO	OIL, DIESEL OLEJ OPALOWY, OLEJ NAPEWODOWY
MAX OIL CONSUMPTION MAKSYMALNE ZUZYCIE OLEJU	3 l / h
ELECTRICAL SUPPLY ZASILANIE ELEKTRYCZNE	230 V / 50 Hz
ELECTRICAL POWER MOC ELEKTRYCZNA	100 W
WEIGHT WAGA	50 kg

**MODEL OF THE NAMEPLATE ON THE BACK OF DEVICE, ON THE COVER**

## 2. Environmental conditions of storage

The 8-30 universal oil heater should be stored in the following conditions:

- temperature -20..85°C
- relative humidity 5..85%
- pressure 800..1200 hPa
- no dust
- environment free from the chemical contamination.

## 3. Environmental conditions of use

The 8-30 universal oil heater should be used in the following conditions:

- temperature 0..30°C
- relative humidity 5..85%
- pressure 800..1200 hPa
- degree of protection against environmental influences IP65
- good ventilation of the heated space

## 4. Characteristic features of the controller

- three-stage power regulation of the furnace 8-19-30 kW,
- preservation of settings in the event of a power supply failure.

## 5. Security aspects

The 8-30 universal oil heater is powered by an alternating current network of 230V / 50Hz. It is equipped with three sensors ensuring safe and economical operation of the device.

1. The bimetallic sensor, located at the furnace chamber, reacts by shorting the points in the thermostat when the temperature exceeds 40°C and opening the points when the temperature drops below 35°C.

2. The bimetallic sensor, located near the supply fan, whose threshold temperature is 100°C, opens the points when this temperature is exceeded and causes the heater to go into emergency mode, disconnecting the fuel supply, thus protecting the fan against overheating or melting of its elements.

3. Micro-switch, weight sensor located under the combustion chamber. Filling the bowl causes the heater to go into emergency mode immediately, disconnecting the fuel supply. This prevents it from spilling out excess non-vaporized fuel outside the combustion chamber, eliminating the possibility of its ignition outside the device. Connection of the heater control panel with other system components (sensors, pump, fan) is made at the factory and during normal operation, for safety reasons, it is not allowed to interfere with the covered and sealed part of the heater controller and to violate the integrity of the wires. Any action of an unauthorized person may result in electric shock (230V AC, 50Hz) and burns

## 6. structure

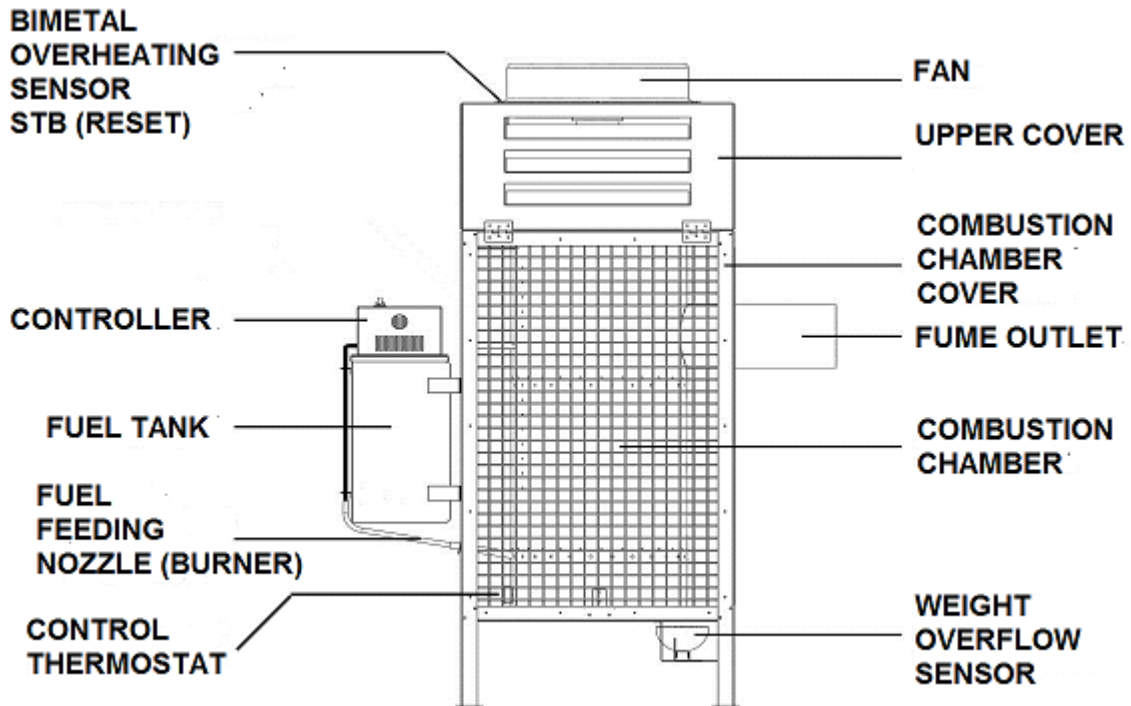

Fig. 1. heater structure

Exit	Description	Info	
1	STB	Thermostat	
2	STB	STB	
3	OVL	Bowl	
4	OVL		
5	T_STER	Control thermostat	
6	T_STER		
7	WENT	Fan output	230V
8	WENT		
9	POWER	Power supply	P
10	POWER		N
11	POWER		L
12	SW1A	Power switch	Para A
13	SW1A		
14	SW1B	Power switch	Para B
15	SW1B		
16	PUMP	Fuel pump	+
17	PUMP		-
18	BZ1	External fuse	
19	BZ1		
P10	Obudowa		

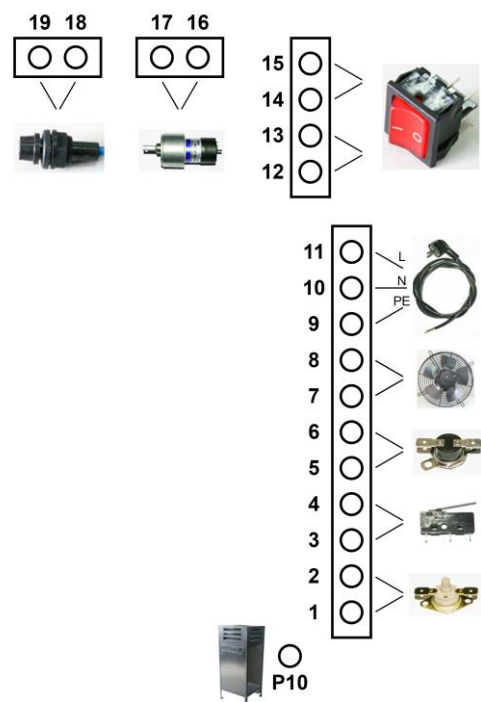

Fig. 2. heater controller scheme.

## 7. Assembly

- check all local regulations,
- place the heater on a flat and hard surface,
- level the device,
- to ensure optimal chimney draft, install at least five meters long, smooth, heat-resistant, vertical chimney pipe (**not aluminum**), preferably made of acid-resistant steel,
- check the tightness of all connections, if necessary, seal them with insulating tape,
- make sure that the elements inside the combustion chamber are correctly placed and the burner is pushed all the way in,
- - check the mains voltage (220-240V / 50Hz) by connecting the heater to the mains and by switching the 0/1 switch,
- - check if in position 1 the switch is red.

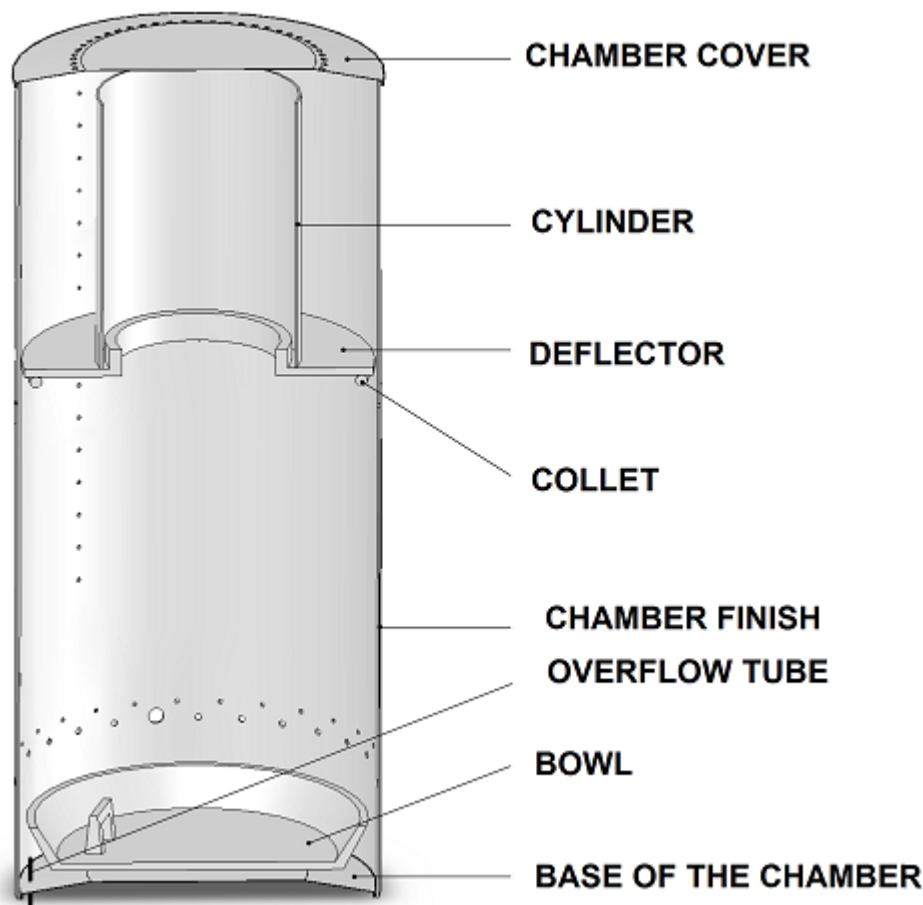

Fig. 3. Structure and components of the combustion chamber

### 7a. Installation of the chimney

A properly constructed chimney installation is necessary to ensure proper combustion.

When performing it, follow the recommendations below:

- the diameter of the exhaust outlet from the device is 130 mm,
- the recommended diameter of the chimney pipe is 130 - 150 mm,
- the minimum height of the chimney with a diameter of 150 mm is 5 meters,
- check the tightness of connections between the chimney elements,
- the wind should freely blow the chimney outlet from all directions - the end of the chimney pipe should be approx. 1 m above the top of the roof,
- if possible, all sections of the chimney should be vertical - avoid horizontal sections, as well as bends of the chimney pipe - if bends are necessary (e.g. two bends in the case of leading the pipe through a wall or window) then the maximum bend angle must not exceed 45°, and the minimum height of the chimney should be increased to 6 meters.

## ATTENTION

When installing the flue gas discharge system, it is recommended to avoid horizontal sections of the chimney pipe.

In order to ensure free outflow of gases, the angle of possible bending of the pipe should not be greater / less than  $45^\circ$ . The chimney outlet must be higher than the top of the roof, preferably approx. 1 m.

The places where the chimney passes through the ceiling, walls or roof must be insulated to avoid fire hazards. It is recommended to use a double-layer insulated chimney pipe wherever there is a possibility of touch contact and outside the building to ensure constant good draft and prevent condensation. Do not place any materials near the heater, even non-flammable ones.

Constant access of air necessary for the proper combustion process must be ensured.

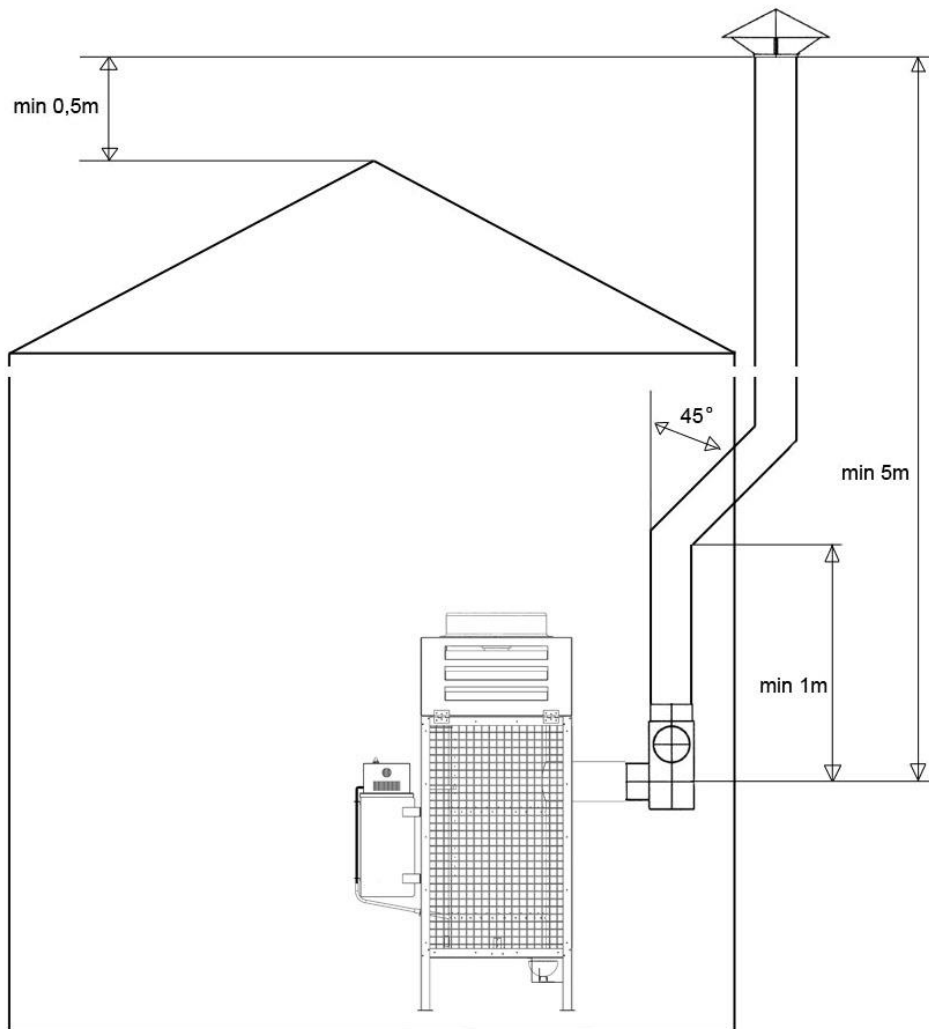

Fig. 4. Chimney installation

## 8. Description of device operation

### 8a. Control panel

The universal oil heater controller type is equipped with a power setting knob, a mains switch, and a fuse socket.



Fig. 5. View of the front control panel.

### 8b. The operation of the device is characterized by the following states:

•Stop	device is ready to start
•Firing up	the initial phase of device operation
•Activity	proper operation of the device
•Stopping	turning off the device
•Overheating	emergency shutdown
•Tank overflow	emergency shutdown

The process of generating heat is carried out by burning gas, which is produced by oil heated to high temperatures. When the device is connected to the mains, it is in standby (**Stop**) mode and no heat is produced, neither the fan nor the pump is running.

Pressing the button marked **NETWORK** in position 1 causes the heater to be ready for firing up (you can see firing up at point 9a). After firing up and heating the heater to a temperature of approx. 40 ° C, the oil feeding pump, and the supply fan are turned on.

**Due to the lower demand for oil when the furnace is not heated, the device should operate at 19kW for at least 15 minutes.** After approx. 15 minutes of operation, when the furnace bowl is sufficiently warmed up and is able to evaporate a larger amount of oil, the power of the device can be switched to 30 kW or less 8kW. When working at the highest power, approx. 3 liters of oil is fed to the furnace.

The heater is turned off by pressing the button marked NETWORK in position "0" on the control panel. At this point, the pump is turned off. The supply fan works until the furnace temperature drops below approx. 35°C (Stopping). After reaching a lower temperature than 35°C, the stove returns to the **Stop** phase.

The heater can be turned off automatically in the following cases:

- overheating of the combustion chamber,
- overflows.

The **overheating** condition is generated by a bimetallic sensor located near the fan. The opening of the contacts signals that the threshold temperature value has been exceeded. The control system turns off the fuel

feeding pump and the fan works until the furnace temperature drops below 35°C. Upon reaching a temperature lower than 35°C, the furnace returns to the **Stop** phase.

To return to normal operation, wait until the furnace cools down (turning off the fan and cooling down the chamber) and press the button on the bimetallic sensor housing (reset). Clean the furnace bowl, taking into account that the bowl and the deflector may still be hot due to the fact that cast iron maintains the temperature for a long time. The heater can then be restarted as described in point 9a.

The **overflow** signal is generated by a mechanical sensor located under the overflow tank. The opening of the contacts signals that the tank is overfilled and turns off the fuel feeding pump, and the fan works until the furnace temperature drops below 35°C. Upon reaching a temperature lower than 35°C, the furnace returns to the **Stop** phase.

To return to normal operation, wait until the heater has cooled down (the fan is turned off and the chamber has cooled down), empty the overflow tank, clean the furnace bowl and the combustion chamber, taking into account that the bowl and deflector may still be hot because cast iron maintains the temperature for a long time. The heater can then be restarted as described in point 9a.

## 9. Heater service

### **ATTENTION!!!**

**DO NOT ADD OIL TO THE FURNACE AND LIGHT WHILE THE FURNACE CHAMBER OR BOWL IS STILL HOT !!!**

**ALWAYS WAIT FOR THE FURNACE PLATE TO COOL DOWN COMPLETELY.  
IF YOU DO NOT FOLLOW THE ABOVE RECOMMENDATION, YOU MAY CAUSE  
UNCONTROLLED IGNITION OF OIL FUMES AND BURN!!!**

### 9a. Starting the device.

- if necessary, drain the water from the fuel tank and fill it with oil (e.g. used oil),
- check the correct operation of the overflow protection mechanism by weighing the cup lever downwards and its spontaneous return, confirmed by a characteristic sound "click",
- check if the burner of the device is pushed as far as possible to the cover of the device (if it is not, it should be pushed in),
- insert the plug of the power cord into the mains socket (230V / 50Hz),
- tilt the upper part of the heater cover and remove the combustion chamber cover, then remove the cylinder and deflector (if necessary, thoroughly clean the combustion bowl and the base on which it is placed, as well as the entire combustion chamber with the sleeve and deflector),
- verify if the furnace bowl is cool and clean, then pour about 250 ml of heating oil or diesel fuel into it,
- assemble the ring and cylinder,
- light the oil using a piece of paper crushed into a ball, set it on fire, and then throw it on the hearth bowl,
- put on the combustion chamber cover, close the upper part of the heater cover,
- press the button marked as **NETWORK** to position 1 and turn the knob of the power setting to the position 19 kW.
- after approx. 10-15 minutes, depending on the room temperature, the fuel pump and the fan are turned on. The heater must run at this power for a minimum of 15 minutes. After approx. 15 minutes of operation, when the furnace bowl is sufficiently warmed up and is able to evaporate a larger amount of oil, you can switch the power of the device to 30 kW or reduce it to 8kW .



## **9b. Shutting down the device**

To turn off the device and end the heating process, on the control panel turn the power setting knob to the fan position and switch the button marked as **NETWORK** to position 0, which will turn off the lamp. The pump will stop feeding fuel to the combustion bowl, and the fan will continue to run until the heater cools down. The extinguishing process depends on the room temperature and the degree of heating of the combustion chamber and may last from 20 to 40 minutes.

**DO NOT disconnect the device from the power supply when the fan is running! Wait for the heater to cool down. The heater is turned off automatically. It should be remembered that after the device is turned off, the cast iron bowl maintains a higher temperature for some time (depending on the ambient temperature) and the heater cannot be re-ignited until the bowl is completely cold! DO NOT throw a hot bowl into the snow, or pour cold water over it to accelerate cooling - a hot bowl, due to a large temperature difference, will crack and will be unusable !!!**

## **9c. Maintenance**

The heater requires very little maintenance. Following the manufacturer's recommendations in this regard will ensure failure-free and safe operation of the device:

- clean the furnace bowl and other elements of the combustion chamber (cylinder, deflector, and cover) daily,
- check the overflow pipe for blockage (the pipe in the lower part of the combustion chamber, directly above the overflow bowl), clean if necessary,
- at least once a week clean the base of the combustion chamber (the element under the furnace bowl),
- check that the air inlet openings in the lower and upper parts of the combustion chamber are not blocked,
- clean the fuel feeding pipe (burner) at least once a week, the maximum working time without cleaning the furnace bowl is approx. 7-14 hours. (depending on the combustion oil used),
- during the heating season, clean the fuel tank and the oil pump filter,
- if the heater will be off for a longer period, carefully clean the combustion chamber and the day tank, then protect them against corrosion by coating them with a thin layer of oil.

### **SEASONAL INSPECTIONS ARE RECOMMENDED** **AT THE AUTHORIZED SERVICE**

## **10. Fault repair**

In the event of a device failure, the list below may help you locate the fault. Generally, they are easy to remove. Possible problems are listed below. The numbers indicate possible causes. The order of the digits shows the probability of a failure.

### **ATTENTION:**

**Before beginning any activities, disconnect the plug from the socket.**

PROBLEM	CAUSE
Pump does not start	6-3-7
The flame goes out and the pump continues to run	2-5-9-10-12
The combustion chamber rumbles.	10-11-12
Soot appears in the combustion chamber and in the chimney.	8-9-10-11-12



Unburned oil remains on the combustion plate.

8-9-11-1 or too much petrol when starting.

Lp.	CAUSE	SOLUTION
1	There is no electrical power.	<ul style="list-style-type: none"> <li>• Check if the plug is in the socket and check the fuses</li> </ul>
2	Water or sediment in the tank.	<ul style="list-style-type: none"> <li>• Clean the tank and filter</li> </ul>
3	The pump motor does not start	<ul style="list-style-type: none"> <li>• Check the STB and overflow protection</li> </ul>
4	Motor and pump are not working	<ul style="list-style-type: none"> <li>• The fuel is too thick or too cold.</li> <li>• Dilute with diesel fuel.</li> <li>• Check the pump operation control thermostat and replace if necessary.</li> <li>• Check the motor and see if the pump it is not dirty inside.</li> <li>• Check the STB and overflow protection</li> </ul>
5	The fuel line is clogged, oil is returning to the tank through the return line	<ul style="list-style-type: none"> <li>• Clean fuel line or replace if necessary</li> </ul>
6	The pump operation control thermostat has not reached the correct temperature	<ul style="list-style-type: none"> <li>• Allow the heater to cool down and restart it</li> <li>• Replace the thermostat</li> </ul>
7	The overflow protection is full	<ul style="list-style-type: none"> <li>• Clean</li> </ul>
8	The safety thermostat (STB) is not working properly or is not working at all.	<ul style="list-style-type: none"> <li>• Reset the thermostat</li> <li>• Replace</li> </ul>
9	Insufficient combustion air supply	<ul style="list-style-type: none"> <li>• Clean the combustion chamber openings</li> <li>• Check the proper operation of the fan</li> </ul>
10	Incorrect air draft	<ul style="list-style-type: none"> <li>• Check if the chimney pipe is installed in accordance with the recommendations in point 7a</li> <li>• Check the tightness of the chimney system</li> <li>• Clean if necessary</li> </ul>
11	The chimney draft is too strong or too fluctuating	<ul style="list-style-type: none"> <li>• Install the draft stabilizer and adjust it for min. 2 mm W.C. (19,6Pa).</li> </ul>
12	The chimney draft is too weak	<ul style="list-style-type: none"> <li>• Check all connections</li> <li>• Reduce the number of bends</li> <li>• Extend the chimney</li> <li>• Insulate the chimney pipe outside the building</li> <li>• Review all information on the flue in the Manual</li> </ul>

### Service parts diagram

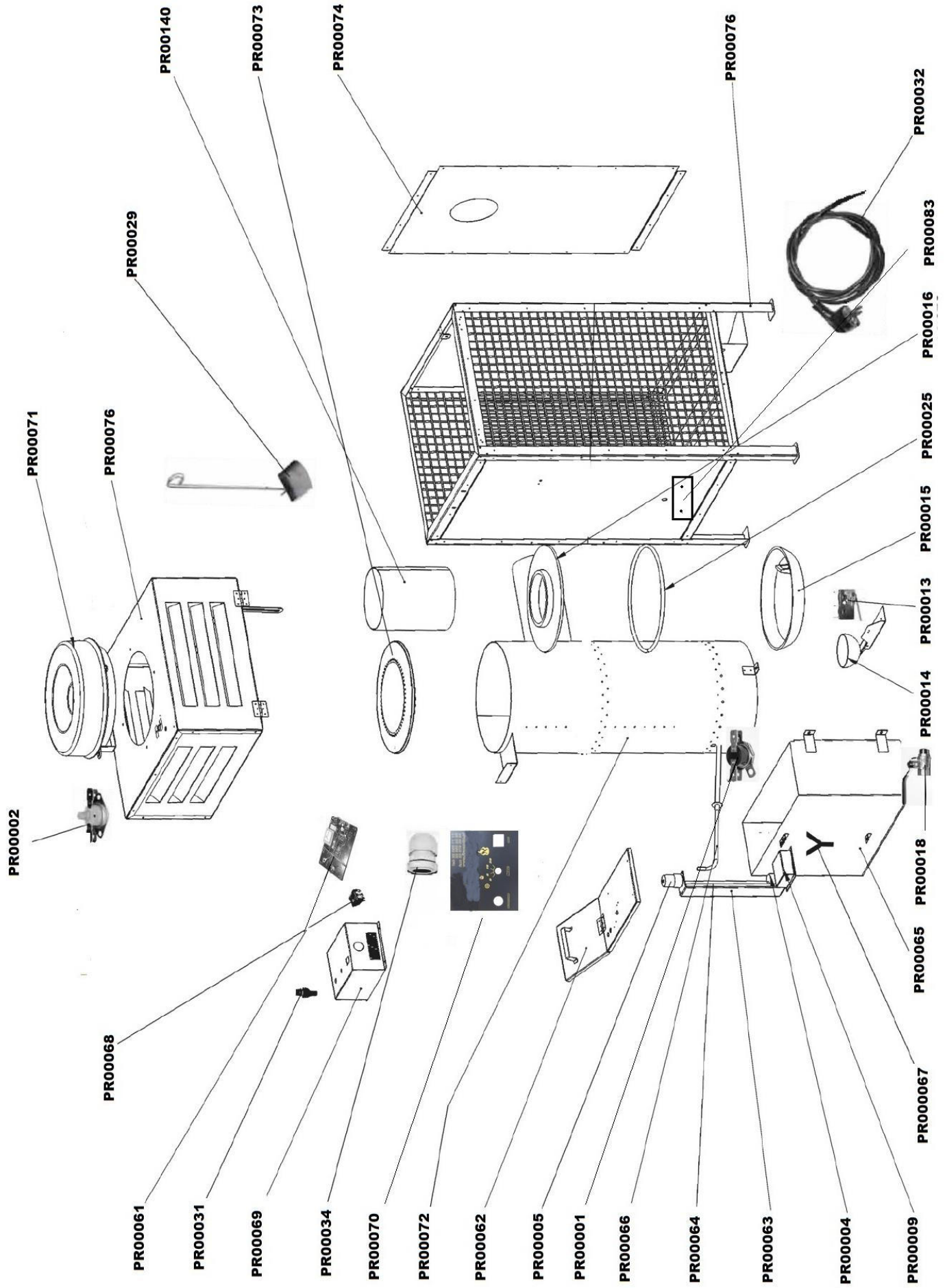

## List of parts

PR00001 - CONTROL THERMOSTAT (T40)  
PR00002 - STB THERMOSTAT (T100)  
PR00004 - FUEL PUMP  
PR00005 - FUEL PUMP MOTOR  
PR00009 - FUEL PUMP FILTER  
PR00013 - OVERFLOW MICRO SWITCH  
PR00014 - OVERFLOW SECURITY - SET  
PR00015 - CAST IRON BOWL  
PR00016 - CAST IRON DEFLECTOR OF COMBUSTION CHAMBER  
PR00018 - FUEL TANK DRAIN VALVE  
PR00025 - COMBUSTION CHAMBER RING  
PR00029 - BURNER FOR CLEANING THE COMBUSTION CHAMBER  
PR00031 - FUSE SEAT  
PR00032 - 230V POWER CABLE WITH A PLUG  
PR00034 - LARGE CABLE GLAND  
PR00061 - CONTROLLER ELECTRONIC BOARD  
PR00062 - FUEL TANK COVER  
PR00063 - FUEL PUMP BRACKET  
PR00064 - FUEL PUMP DRIVE SHAFT  
PR00065 - FUEL TANK  
PR00066 - FEED PIPE TO COMBUSTION CHAMBER  
PR00067 - TEE FOR FUEL LINES  
PR00068 - FURNACE SWITCH  
PR00069 - CONTROLLER COVER  
PR00070 - DRIVER STICKER  
PR00071 - 250mm AXIAL FAN  
PR00072 - COMBUSTION CHAMBER  
PR00073 - COMBUSTION CHAMBER COVER  
PR00074 - REAR COVER OF COMBUSTION CHAMBER  
PR00076 - STOVE CONSTRUCTION INCLUDING FAN CASING  
PR00083 - BLANKING FOR CONTROL THERMOSTAT  
PR00140 - COMBUSTION CHAMBER CYLINDER

**Postadress:**

TRÄDGÅRDSTEKNIK AB  
Helsingborgsvägen 578, Varalöv  
262 96 ÄNGELHOLM

Telefon : 0431-222 90  
Bg.nr : 5743-7980  
Org.nr : 556409-6120

**URL:**

[www.tradgardsteknik.se](http://www.tradgardsteknik.se)  
E-postadress:  
[info@tradgardsteknik.se](mailto:info@tradgardsteknik.se)